

# WaterSystems

## NSPHE Series



### Applications

Designed for both high pressure and high capacity, these pumps cover a wide range of applications and are ideal for lawn or turf sprinkling and can also be used as a standby pump for fire protection.

### Features

- **BUILT-IN CHECK VALVE** - Suction check valve facilitates priming and prevents back flow or syphoning, 1½", 2" & 2½" NPTF.
- **DISCHARGE** - NPTF 1½" or 2".
- **IMPELLER** – Noryl glass filled, provides smooth surface for efficient operation, corrosion resistant, enclosed type for higher pressures; the 3 & 5 HP units have cast gray iron impellers.
- **SEAL** – Mechanical, self-lubricating, self-adjusting for wear, no maintenance required.
- **CASING** – Cast gray iron, large housing to assure self priming, eliminating need for foot valve or priming device.
- **DIFFUSER** – Cast gray iron, built-in on all models, improves pump efficiency.
- **MOTOR** – CSA approved motors ranging in sizes from ¾ to 5 HP.

1, 1½, and 2 HP single phase are square flange jet pump motors, with higher than NEMA service factor.

1, 1½, and 2 HP have thermal overload protection.

3 HP and 5 HP motors are JM frame, without thermal overload protection.

## Dimensional Outline

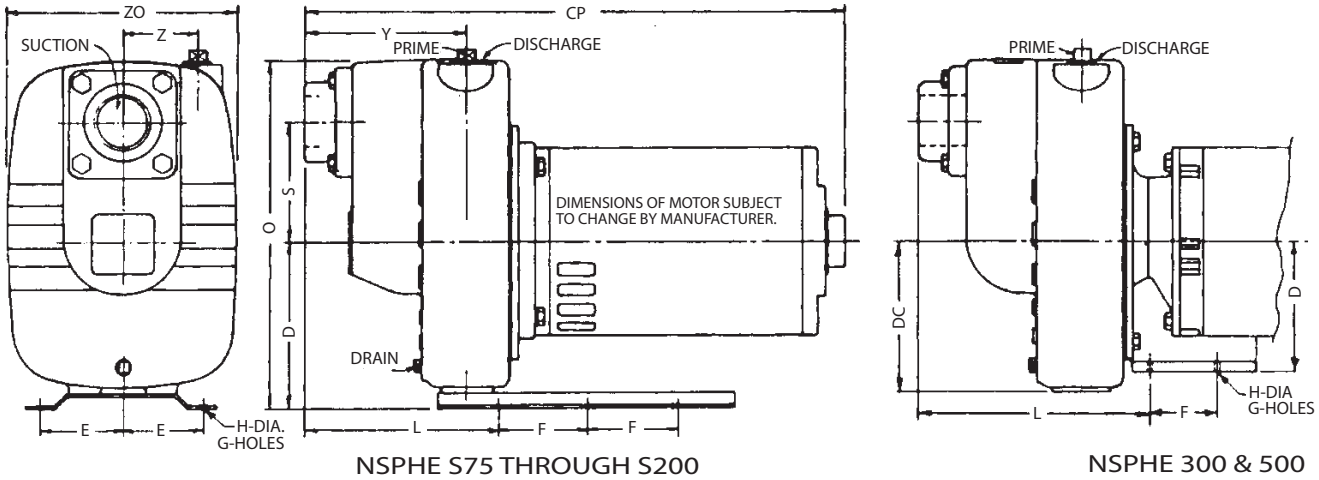

NSPHE S75 THROUGH S200

NSPHE 300 & 500

Model	Suction NPT	Discharge NPT	CP	D	DC	E	F	G	H	L	O	S	Y	Z	ZO
NSPHE-300	2"	2"	23.25	4.50	5.00	3.75	5.00	4.00	0.44	14.75	13.25	6.00	6.38	3.00	9.75
NSPHE-300-3	2"	2"	23.75	3.50	5.56	2.75	5.00	4.00	0.38	14.50	12.00	6.00	6.38	3.00	9.75
NSPHE-500	2 1/2"	2"	23.38	4.50	5.56	3.75	2.75	4.00	0.40	15.12	13.88	5.75	6.38	3.00	9.75
NSPHE-500-3	2 1/2"	2"	23.38	4.50	5.56	3.75	2.25	4.00	0.40	15.12	13.88	5.75	6.38	3.00	9.75

\*Dimensions measured in inches

## Performance Chart

Model No.	HP	Discharge Pressure in PSI at 5 ft. Lift						Max. PSI
		10	20	30	40	50	60	
Capacities in U.S. GPM								
NSPHE-300	3	124	110	95	77	54	-	59
NSPHE-500	5	170	165	146	128	109	85	74

## NSPHE Series - Electric Motor Driven

NSPHE SERIES - ELECTRIC MOTOR DRIVEN						
Model No.	Order No.	HP	SF	Suct. NPT	Disch. NPT	Ship Wt. (lbs.)
NSPHE-300	614404	3	1.15	2"	2"	134
NSPHE-300-3	614405	3	1.15	2"	2"	110
NSPHE-500	614406	5	1.15	2 1/2"	2"	140
NSPHE-500-3	614407	5	1.15	2 1/2"	2"	130

## Performance Curve

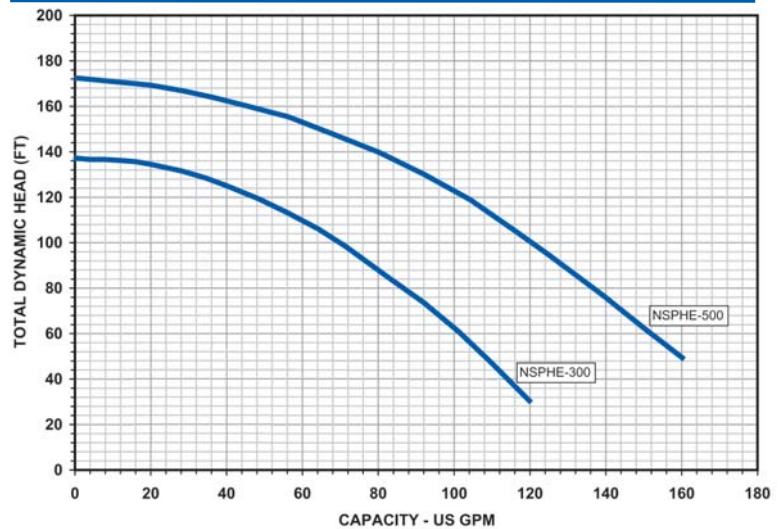

P.O. Box 12010  
 Oklahoma City, OK 73157-2010  
 Phone: 1.800.701.7894  
 Fax: 1.800.678.7867  
 www.LittleGiantPump.com